

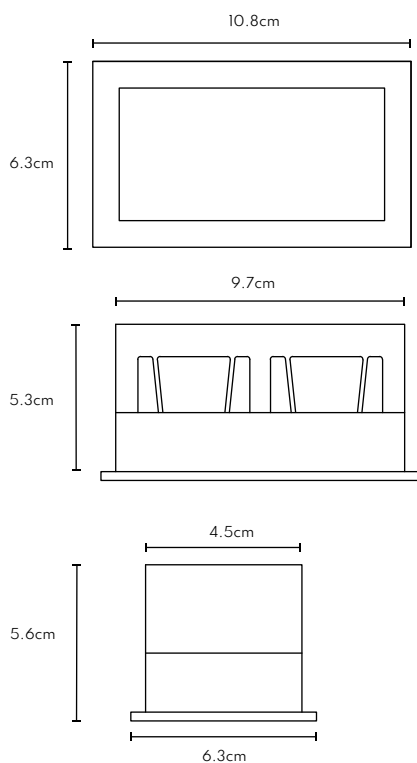

DESCRIPCIÓN

Marco de aluminio del sistema MACEDONIA.
Módulo doble para empotrar en plafón. Color blanco.



ESPECIFICACIONES

Alto	Largo	Ancho
5.3cm	10.8cm	6.3cm
Color	Peso	
○	90g	